

TYPAR® FLANGEFLASH

INSTALLATION GUIDE

REQUIRED TYPAR® PRODUCTS

- TYPAR® FlangeFlash (6" Double-Sided Flashing)
- TYPAR® Flexible Flashing (3", 6", or 9")
- TYPAR® Construction Tape (2" or 3")
- TYPAR® HD Sealant, TYPAR® Liquid Flashing

OTHER PRODUCTS NEEDED

- Backer Rod (Optional)
- J-Roller or Flashing Paddle
- Scissors

FOR NON-FLANGED WINDOW OPENINGS

STEP 1: PREPARE THE WEATHER-RESISTANT BARRIER (WRB)

- Cut a rectangle OR an "I" in the TYPAR WRB at the window opening:
 - Vertical cut from head to sill.
 - Horizontal cuts at head and sill, stopping at opening width.
- At the head, make two 45° slits (approximately 8") angled up and away from each top corner.
- Fold the head flap up and secure with TYPAR Construction Tape.
- Fold side flaps into the opening and secure inside.

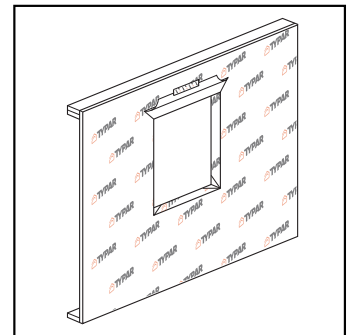
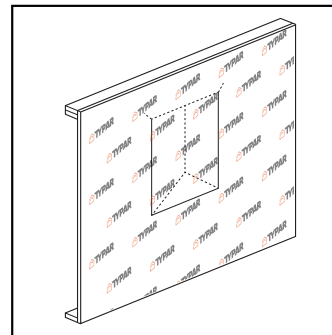

STEP 2 : APPLY SILL FLASHING

Create a sill pan using TYPAR Flexible Flashing. Cut a piece that is 12" longer than the length of the rough opening window sill. Carefully peel off the release liner. Place the flashing in the center of the rough opening and work your way toward the corners and then up the sides. Note: The flexible flashing should overlap to the outside of the wall by 2"-3". Only stretch the flashing in the corners. Alternatively, you could create a sill pan by installing a TYPAR straight flashing along the bottom sill and installing TYPAR Flexible Flashing on the corners only. If needed, secure the fanned edges of the TYPAR Flexible Flashing with a plastic-capped nail or plastic-capped staple.

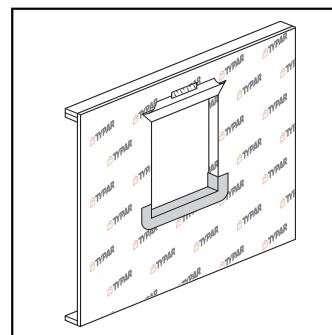

FOR NON-FLANGED WINDOW OPENINGS

STEP 3: APPLY HEAD FLASHING

- Cut TYPAR FlangeFlash 12" wider than the rough opening.
- Center the flashing, ensuring the flashing continues at least 6" beyond both sides of the window.
- Remove one side of the release paper and apply to the frame of the window.
- Starting at the connection of the jamb and head, make a cut parallel to the window head.
- Fold the cut piece onto the jamb of the window frame.

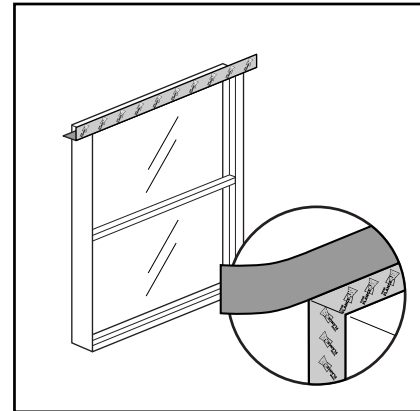

STEP 4: APPLY JAMB FLASHING

- Cut two pieces of TYPAR FlangeFlash, each 6" greater than the length of the jamb.
- Align the FlangeFlash about 1"-2" below the top edge of the head flashing. Jamb flashing adhesive must come in contact with head flashing adhesive and overlap by 1".
- Remove one side of the release paper and apply to the frame of the window.
- Starting at the connection of the jamb and head, make a cut parallel to the window frame.
- Fold the cut piece onto the head of the window frame.
- Repeat on opposite side.
- Apply firm pressure to the flashing on all three sides of the window frame with a J-roller or flashing paddle.

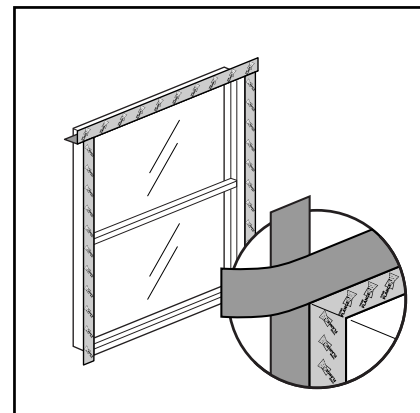

STEP 5: ADDITIONAL CORNER PROTECTION (OPTIONAL)

- If a gap is present where the head and jamb flashing cuts meet, seal it with one of the following methods:
- Two 3"x3" pieces of TYPAR® Flexible Flashing.

OR

- Enough TYPAR® HD Sealant or TYPAR® Liquid Flashing to fully cover the voids.

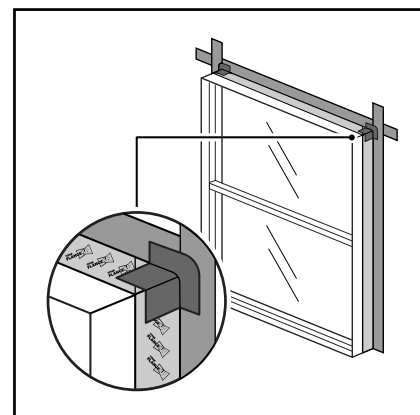

FOR NON-FLANGED WINDOW OPENINGS

STEP 6: INSTALL THE WINDOW

- Set the window according to manufacturer instructions.
- After setting, remove any remaining release liners and press the TYPAR FlangeFlash firmly to the WRB.
- (Optional) Use backer rod and sealant at the interior around the jambs and head of the window.

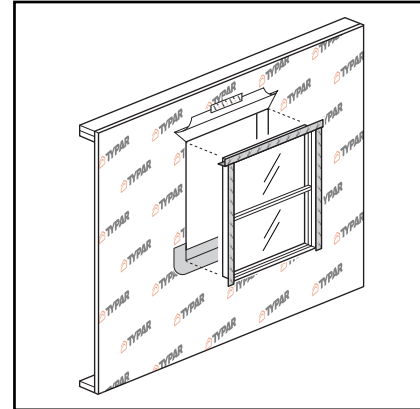

STEP 7: FINAL WRB INTEGRATION

- Fold the TYPAR® WRB head flap back down.
- Trim 1"-2" off the flap edge if needed.
- Seal all cuts with TYPAR® Construction Tape, starting with the horizontal cuts and followed by the angled cuts.

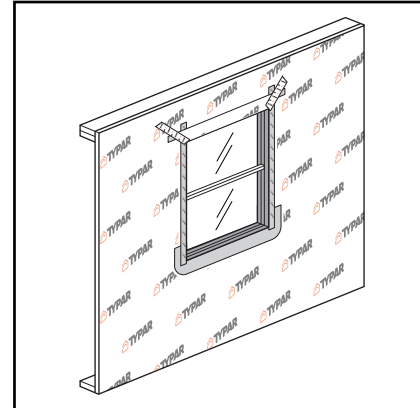

FOR NON-FLANGED DOOR OPENINGS

STEP 1: PREPARE THE WRB

- Cut a rectangle OR an "I" in the TYPAR® WRB at the door opening:

 - Vertical cut from head to sill/threshold.
 - Horizontal cuts at head and sill, stopping at opening width.

- At the head, make two 45° slits (approximately 8") angled up and away from each top corner.
- Fold the head flap up and secure with TYPAR® Construction Tape.
- Fold side flaps into the opening and secure inside.

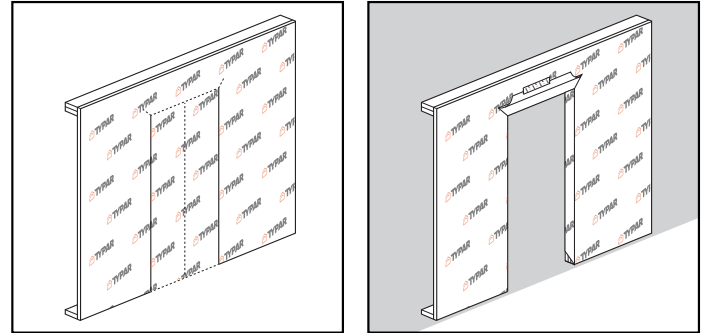

STEP 2: APPLY HEAD FLASHING

- Cut TYPAR FlangeFlash 12" wider than the rough opening.
- Center the flashing, ensuring the flashing continues at least 6" beyond both sides of the door.
- Remove one side of the release paper and apply to the frame of the door.
- Starting at the connection of the jamb and head, make a cut parallel to the door head.
- Fold the cut piece onto the jamb of the door frame.

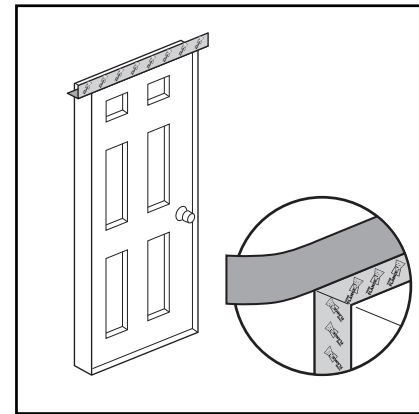

STEP 3: APPLY JAMB FLASHING

- Cut two pieces of TYPAR FlangeFlash, each 6" greater than the length of the jamb.
- Align the FlangeFlash about 1"-2" below the top edge of the head flashing.
- Remove one side of the release paper and apply to the frame of the door.
- Starting at the connection of the jamb and head, make a cut parallel to the door frame.
- Fold the cut piece onto the head of the door frame.
- Repeat on opposite side.
- Apply firm pressure to the flashing on all three sides of the door frame with a J-roller or flashing paddle.

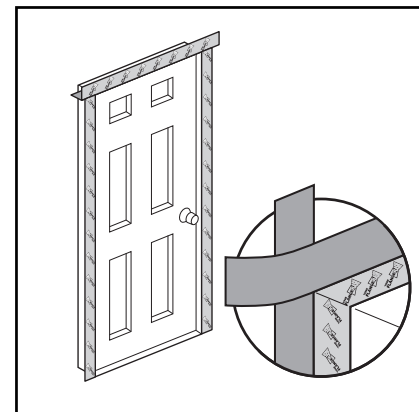

FOR NON-FLANGED DOOR OPENINGS

STEP 4: ADDITIONAL CORNER PROTECTION (OPTIONAL)

- If a gap is present where the head and jamb flashing cuts meet, seal it with one of the following methods:
- Two 3"x3" pieces of TYPAR® Flexible Flashing

OR

- Enough TYPAR® HD Sealant or TYPAR® Liquid Flashing to fully cover the voids.

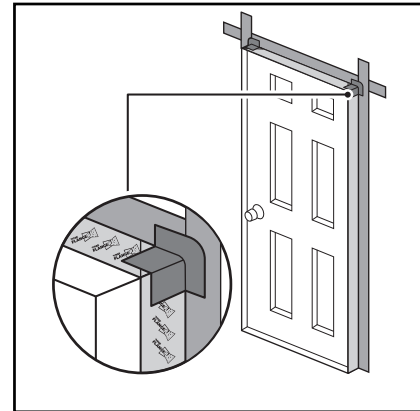

STEP 5: PROTECT THE SILL

Slab on Grade

- Apply a minimum 3/8" rounded bead of sealant along the interface between the framing and the concrete on both sides of the rough opening. Next, toward the back of the door frame opening, apply three 3/8" rounded beads of TYPAR HD sealant, or Liquid Flashing, along the sill and at least 6" up the frame of the rough opening.

Doors with Step-Down Landings

- Create a sill pan by cutting TYPAR 6" or 9" Flexible Flashing to door width plus 12". (Example: A 3068 door requires 4'.)
- Center over the rough opening.
- Adhere to the back of the sill so that 2"-3" will be folded onto the exterior face of the wall.
- Apply sealant as described in the "Slab on Grade" application above.

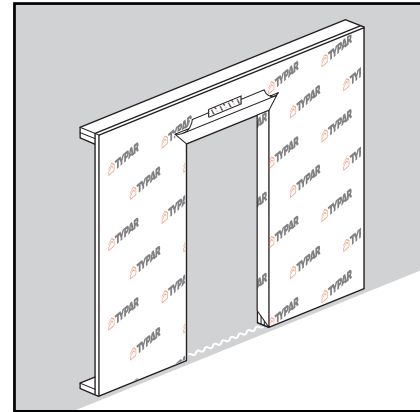

STEP 6: INSTALL THE DOOR

- Set the door according to manufacturer instructions.
- After setting, remove any remaining release liners and press the TYPAR FlangeFlash firmly to the WRB.
- (Optional) Use backer rod and sealant at the interior around the jambs and head of the door.

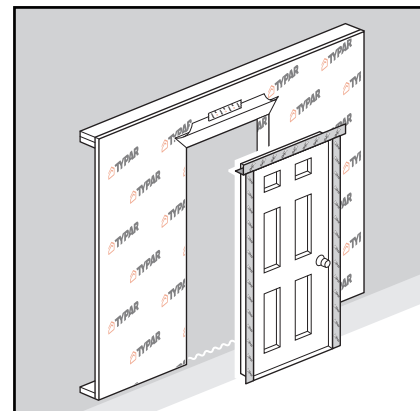

FOR NON-FLANGED DOOR OPENINGS

STEP 7: INSTALL DRIP CAP FLASHING (OPTIONAL)

- If desired, install the drip cap flashing. Cover it with a TYPAR self-adhered flashing, extending at least 1" beyond each end of the drip cap or the FlangeFlash— whichever is wider. This step can also be completed after final WRB integration.

STEP 8: FINAL WRB INTEGRATION

- Fold the TYPAR® WRB head flap back down.
- Trim 1"–2" off the flap edge if needed.
- Seal all cuts with TYPAR® Construction Tape, starting with the horizontal cuts and followed by the angled cuts.

